

Knowledge organiser title	Specification topic	Page number
<a href="#">Energy the basics</a>	Energy	<u>2</u>
<a href="#">Generating electricity</a>	Electricity	<u>4</u>
<a href="#">Circuits 1</a>	Electricity	<u>7</u>
<a href="#">Particle model</a>	Particle model of matter	<u>10</u>
<a href="#">Energy calculations</a>	Energy	<u>16</u>
<a href="#">Circuits 2</a>	Electricity	<u>18</u>
<a href="#">Atomic structure (radioactivity)</a>	Atomic structure	<u>22</u>

How to use this knowledge organiser:

- Click on the name of the topic/page number/practical method you want to revise
- Use the 'Back to contents' at the top of each page to return here

Required practical	Page number	Specification required practical number
<a href="#">Thermal insulation</a>	<u>3</u>	2
<a href="#">Resistance of a wire</a>	<u>9</u>	3
<a href="#">Resistors in series and parallel</a>	<u>9</u>	3
<a href="#">Density</a>	<u>13</u>	5
<a href="#">Specific heat capacity</a>	<u>17</u>	1
<a href="#">IV characteristics</a>	<u>19</u>	4
<a href="#">Working scientifically terms</a>	<u>27</u>	

Energy stores and systems	Work done	Energy transfers	Conservation of energy	Calculating power	Measuring power	Efficiency	Reducing wasted energy	Thermal insulation practical (2 lessons)
---------------------------	-----------	------------------	------------------------	-------------------	-----------------	------------	------------------------	--

**Key Words**

Key Word	definition
Energy	Measured in Joules (J)
Power	Rate of energy transfer. Measured in Watts (W)
Work done	Amount of energy transferred, measured in joules (J)
Energy changes	Discuss whether the size of the store is <b>increasing, decreasing</b> or <b>staying the same</b> .
Efficiency	How much output is useful compared to the input. Can be energy or power.
System	An object or group of objects involved in an energy transfer
Dissipated	Spread out into the surroundings
Lubrication	Used to reduce thermal energy due to friction between moving parts
Conductivity	Measures the rate of thermal energy transfer by conduction through a material

**Misconceptions**

Energy does not get 'used up'  
It transfers to a different store

Energy and power are not the same thing  
Energy is stored (joules), power measures how quickly energy is transferred (watts)

Work done is not different to energy transferred  
Work done is another way to say energy is being transferred

Insulation does not only helps to reduce energy transfer from hot objects  
Insulation reduces the rate of thermal energy transfer from whatever is hotter to whatever is colder

**Key questions**

What are the eight ways energy is stored?

What is meant by the law of conservation of energy?

What is meant by power? State the units of power.

Explain how lubrication/insulation work to improve efficiency.

State the equations for calculating work done and power.

## Energy Stores

Energy Store	Description
Kinetic energy	Energy due to motion.
Gravitational Potential energy	Energy stored due to object's height in a gravitational field
Chemical Potential energy	Energy stored in chemical bonds.
Elastic Potential energy	Energy stored in stretched or compressed objects.
Magnetic energy	Energy stored by separated magnets
Electrostatic energy	Energy stored by charged objects
Nuclear Potential energy	Energy stored within the nucleus of an atom
Thermal/internal energy	Energy stored in an object that effects its temperature

## Work done

Work is done to transfer energy from one store to another.

## Work done equation

$$\text{Work done (J)} = \text{Force (N)} \times \text{Distance (m)}$$

## Power

Power is the rate at which energy is transferred or the rate at which work is done.

### Power equation

$$\text{Power (W)} = \frac{\text{Energy transferred (J)}}{\text{Time taken (s)}} \quad \text{or} \quad \text{Power (W)} = \frac{\text{Work done (J)}}{\text{Time taken (s)}}$$

## Energy Transfers

Electrically – electrical current moves energy from a supply to a load

Heating – thermal energy transfers from hot to cold (conduction and convection - involves particles)

Radiation – waves transfer energy (light, sound, thermal energy transfer without particles)

Mechanically - forces transfer energy

## Conservation of energy:

Energy can be transferred usefully, stored or dissipated, but cannot be created or destroyed.

## Heating through Friction

- Car brakes - kinetic decreases, internal energy increases.
- The force that does work to cause this change is called FRICTION.

## Thermal insulation practical (triple)

1. Use a kettle to boil water.
2. Start with a beaker with no insulation.
3. Put 80 cm<sup>3</sup> of this hot water into a beaker.
4. Use a piece of cardboard as a lid with a hole for a thermometer
5. Record the temperature of the water and start using the stopwatch.
6. Record the temperature of the water every 2 minutes for 20 minutes.
7. Repeat steps 1–5 using different materials wrapped around the beaker.

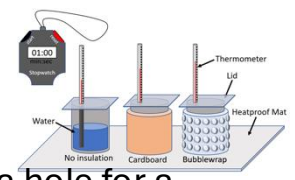

Ensure volume and starting temperature are always the same

<b>Mains electricity Plugs</b>	<b>National grid</b>	<b>Energy resources Non renewables</b>	<b>Energy resources Renewables</b>	<b>Comparing energy resources</b>	<b>Calculating Ep</b>	<b>Biofuels</b>	<b>Plugging in to the National Grid</b>
--------------------------------	----------------------	--	------------------------------------	-----------------------------------	-----------------------	-----------------	---

**Key Words**

**Misconceptions**

Key Word	Definition
Alternating Potential Difference	Changing polarity (constantly switching between + and -) and size (constantly changes direction)
Direct Potential Difference	Constant polarity and size (flows in same direction).
Fossil fuels	Coal, oil and gas.
Mains Electricity	An a.c supply, in the UK it has a frequency of 50Hz a value of 230V.
Renewable Energy Resource	An energy resource that can be replenished as it is used.
Step-Down Transformers	Devices found between the transmission cables and the consumer that lower the potential difference of the power to make it safe.
Step-Up Transformers	Devices that increase the potential difference generated by a power station.
The National Grid	The network of transformers and cables that connect consumers to power stations.

Power lines (overhead) are not usually insulated – it is very dangerous to fly kites/build tents near them	Birds are not resistant to electric shocks – they can sit on power lines because there is no connection to earth	Renewable resources are not better than non-renewables: they all have different advantages and disadvantages	All renewable resources are not good for the environment – some cause loss of habitats
--	--	--	--

**Key questions**

What is the structure and function of a three-pin plug?

What is the national grid and why is it needed?

What are the energy resources available on earth?

How can the gravitational potential energy stored by an object be calculated?

What are the advantages and disadvantages of using energy resources?

Three pin plugs	
<b>Earth Wire</b>	The green and yellow striped safety wire that prevents an appliance from becoming live. Kept at 0V.
<b>Insulation</b>	The coating around power cables that prevents electrocution and is colour coded to allow for easy identification.
<b>Live Wire</b>	The brown coloured wire that carries the alternating potential difference of 230V from the supply in a mains power supply.
<b>Neutral Wire</b>	The blue coloured wire that completes the circuit in a mains power supply. Kept at 0V.

Electrical appliances are connected to the mains with a three-core cable, the three pins on a plug are the ends or terminals of the three wires.

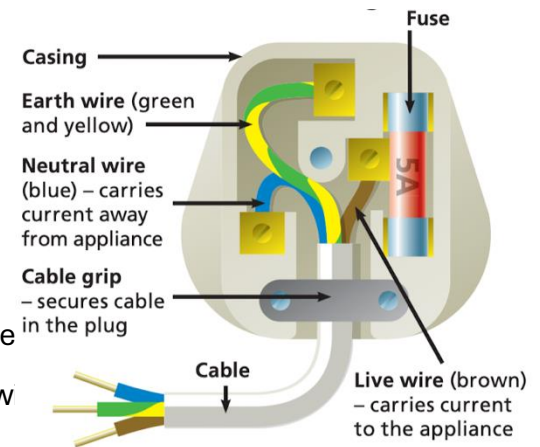

Some appliances use a two-core cable (don't need an earth wire) because they are made of plastic (an insulator)

### Earth wires

- Safety wire connected to metal case of an appliance, kept at 0V
- Only carries a current if there is a fault and case becomes live (provides safe path for current to prevent electric shocks)
- Has low resistance
- Causes fuse to melt/blow to disconnect circuit and prevent electric shocks

Earth wire connected to the metal case

Any connection between the live and earth wire is very dangerous due to large potential difference which could cause electric shock or overheating (fires)

Even if the switch is off the live wire is still dangerous, if touched it can complete the path to earth (through you standing on the ground) and give you an electric shock

### National grid

- Step-up transformers: increase the potential difference from power station to transmission cables (which decreases the current)
- Step-down transformers: decrease, to a much lower value, the pd for domestic use.
- Reason: for a given power ( $P=IV$ ), increasing potential difference reduces current, which reduces energy losses due to heating in the transmission cables (increases efficiency).

### Gravitational potential energy equation

Gravitational potential energy (J) = mass (kg) x gravitational field strength (N/kg) x height (m)

$$E_p = m \times g \times h$$

**Main energy resources available on Earth**

- fossil fuels - burn (coal, oil, gas ) N ✓
- nuclear fuel - nuclear fission reaction in nuclear power stations N ✓
- bio-fuel - burn products from plants/animals R ✓
- wind - wind turbines R X
- hydroelectricity- water falling through turbines from behind dams R ✓
- geothermal - heat from radioactive rocks underground R ✓
- the tides - tidal water moving through turbines (in a barrage) R ✓
- the Sun - solar panels or solar cells R X
- water waves - waves rocking floats/moving air through a turbine R X

**Political, Social, Economic, Ethical, Environmental Issues**

- fossil fuels - → CO<sub>2</sub> causing global warming
- nuclear fuel - danger of explosion / leakage & waste very toxic (radioactive) for many years
- bio-fuel - → CO<sub>2</sub> but it came from the atmosphere originally, so no overall increase, growing bio-fuels instead of food can lead to shortages/price increases
- wind - wind turbines are an eyesore
- hydroelectricity - valleys must be flooded, displacing wildlife and farmers
- geothermal - only some places are suitable (e.g. Iceland due to volcanic activity)
- the tides - barrage destroys environments for wildlife
- the Sun - good for remote areas but solar cells are expensive
- water waves - viable large scale machines not yet built

Key:

- renewable: being replenished as it is used (marked R)
- non-renewable: cannot easily be replenished so will run out (marked N)
- reliable resources marked ✓ (can be depended on)
- unreliable resources marked X (e.g. wind doesn't always blow, Sun sometimes behind clouds, these are unpredictable)
- uses of energy resources include: transport, electricity generation, heating

**Direct and alternating potential difference**

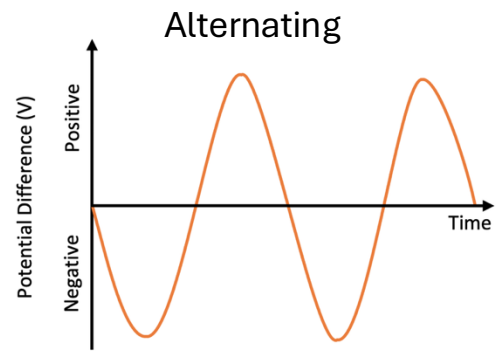

Polarity and size constantly changing (from mains from power stations)

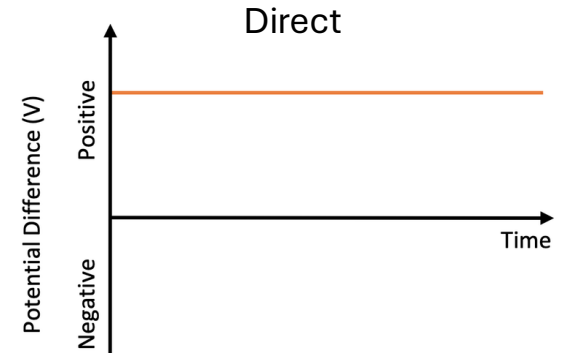

Polarity and size stays the same (from batteries and cells)

Circuit symbols	Current and charge	$V=IR$	Current in series and parallel	Potential difference in series and parallel	Circuit problem solving	Resistance of a wire	Resistors in series and parallel	Alternating and direct potential difference
-----------------	--------------------	--------	--------------------------------	---	-------------------------	----------------------	----------------------------------	---

## Key Words

Key Word	Definition
<b>Amperes (Amps)</b>	The unit of current.
<b>Coulomb</b>	The unit of charge.
<b>Electrical Current</b>	The rate of flow of electrical charge
<b>Electrical Work</b>	When charge flows in a circuit, electrical work is said to be done.
<b>Ohms</b>	The unit of resistance.
<b>Potential Difference</b>	The energy transferred to or by each unit of charge, measured in volts.
<b>Power</b>	The rate of energy transfer. In electrical components, the power is found by multiplying p.d. by current.
<b>Resistance</b>	A measure of the opposition to current flow.
<b>Volt</b>	The unit of potential difference.
<b>Work</b>	Transfer of energy.

## Misconceptions

Current is not used up as it flows around a circuit

Cells and batteries do not store current. Cells and batteries store chemical energy.

Potential difference does not flow through components, it measures the difference in energy across the component.

A cell or battery does not produce a fixed current, the current depends on the potential difference of the cell and resistance of the circuit

## Key questions

What is the difference between series and parallel circuits?

What is current and what does it do in series and parallel circuits?

What is potential difference and what happens to it in series and parallel circuits?

How are length of wire and resistance related?

How does connecting resistors in series and parallel effect total resistance?

Series and parallel circuits

Current, resistance and potential difference

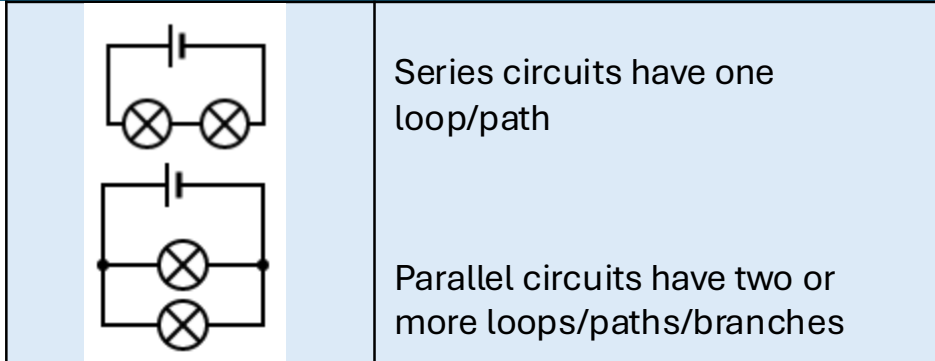

Series circuits have one loop/path

Parallel circuits have two or more loops/paths/branches

Potential difference or voltage – energy transferred to or by each coulomb of charge, needed for a current, measured in volts (V)

Resistance – how difficult it is for current to flow, measured in ohms ( $\Omega$ )

Higher resistance means lower current for a give potential difference

$$V = I \times R$$

Potential difference (V) = current (A) x resistance ( $\Omega$ )

Current	Series: is the same everywhere. Parallel: splits/rejoins at branches
Potential difference	Series: pd of power supply is shared between components. Parallel: is same as power supply across each loop/branch
Resistance	Series: total R = sum of resistances of all components Parallel: total R is reduced as current can follow more paths

Circuit components

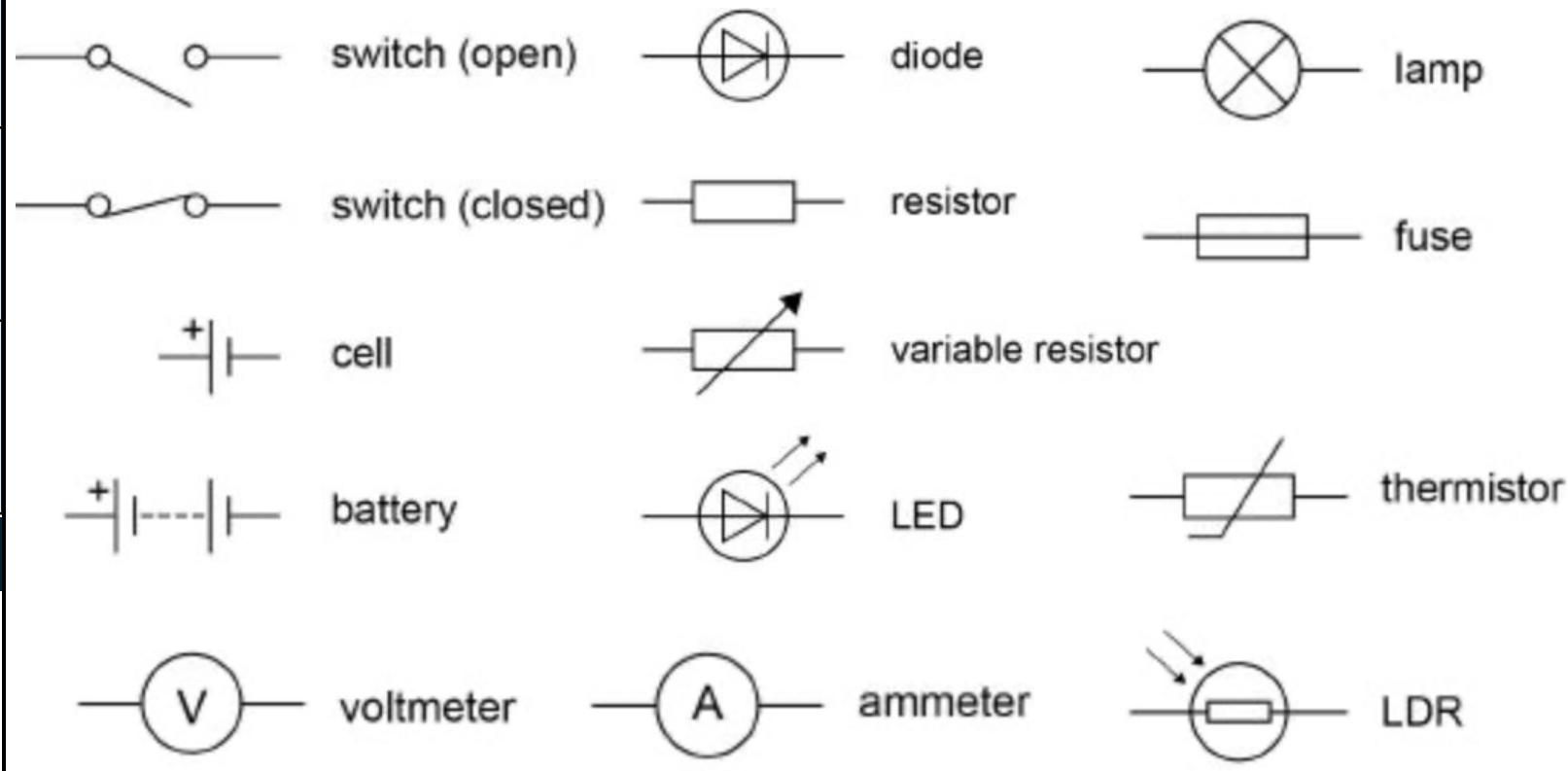

Charge and current

Charge – electrons with negative charge, measured in coulombs (C)

Current – rate of flow of charge, measured in amps (A)

$$Q = I \times t$$

Charge (C) = current (A) x time (s)

Types of potential difference

**Direct potential difference** flows in the same direction, it has a constant magnitude (size) and a constant polarity. Produced by batteries, cells and solar panels



Switching the poles of the supply will swap the direction of flow (blue line)

**Alternating potential difference** constantly changes polarity (between positive and negative) which reverses the direction of the current frequently. The rate at which the potential difference switches from positive to negative is called the frequency of the supply (50 Hz in the UK). Produced by power stations.

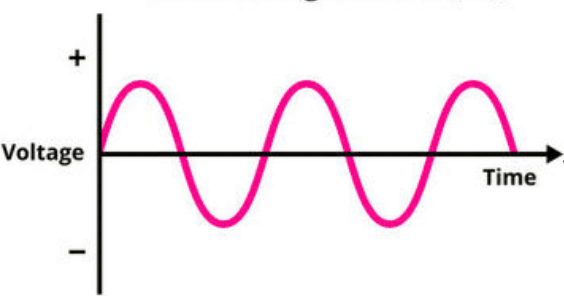

Has changing magnitude. +ve and -ve values indicate the direction of current flow.

Resistance

Resistance is affected by:

- The length of the wire or component - In a longer wire **electrons** must pass more **ions**. Passing more **ions** means more collisions between the **electrons** and the **ions** = greater resistance
- The thickness of the wire or component - In a thin wire there are fewer **electrons** to carry the current = greater resistance
- The temperature of the wire or component – at higher temperatures **ions** vibrate faster and further. **Electrons** are more likely to collide with **ions** if the **ions** are vibrating more = greater resistance
- The material the wire or components is made of - Some materials have more densely packed **ions** = greater resistance

Resistance of a wire practical

1. Set up the equipment as shown in the diagram
2. Place the crocodile clips on the wire as far apart as possible.
3. Measure the distance between the crocodile clips in m using a ruler.
4. Turn on the power supply and immediately record the voltmeter and ammeter readings.
5. Turn off the power supply.
6. Calculate the resistance of the wire using  $R = V / I$
7. Repeat steps 2-6 reducing the distance between the crocodile clips each time.

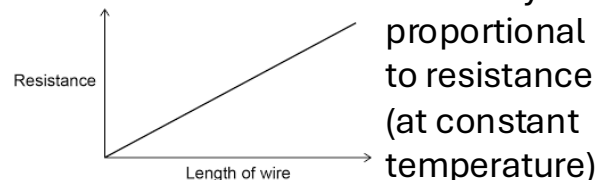
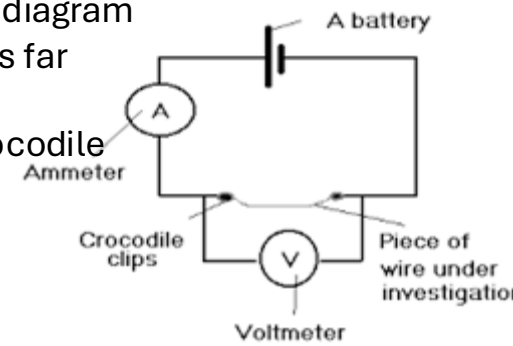

Resistors in series and parallel

1. Connect the resistors in series as shown in the diagram (below left)
2. Record the values for current and potential difference
3. Calculate the resistance using  $R = V / I$
4. Now connect the resistors in parallel as shown in the diagram (right)
5. Repeat steps 2 and 3 for resistors in parallel

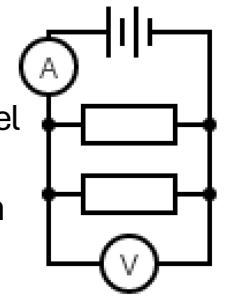
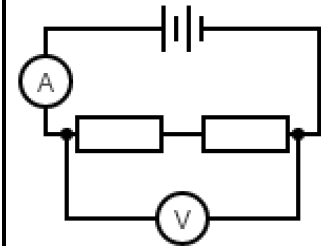

Total resistance in series = sum of individual resistors (adding resistors increases resistance)

Total resistance in parallel = less than resistance of one resistor (adding resistors decreases resistance as current increases due to more paths)

<b>Atoms and isotopes</b>	<b>Forming ions and size of atoms</b>	<b>Atom model</b>	<b>States of matter</b>	<b>Density</b>	<b>Density practical 1</b>	<b>Density practical 2</b>	<b>Internal energy</b>	<b>Changes of state</b>	<b>Specific latent heat</b>	<b>Fluid pressure</b>	<b>Fluid pressure (triple)</b>
---------------------------	---------------------------------------	-------------------	-------------------------	----------------	----------------------------	----------------------------	------------------------	-------------------------	-----------------------------	-----------------------	--------------------------------

**Key Words**

Key Word	Definition
Model	Models are used all the time in science. A model represents the real world and can explain many things about the universe. However, models are never perfect and there are limits to what they can explain. That doesn't stop them being extremely useful though!
Particle model	The model that represents molecules or atoms as small, hard spheres. The important things to think about when using the particle model are the arrangement of the particles in each state of matter and the kinetic energy of the particles.
State of matter	The physical arrangement of particles determines the state of a particular substance: solid, liquid or gas. Changing from one state of matter to another is a physical process, NOT a chemical process. No new substance is produced, and if you reverse the state change, you have a substance with exactly the same properties as the stuff you started with.
Density	The quantity that defines how much material (i.e. mass) is in a certain volume. See equation.

**Misconceptions**

Heating does not cause particles to get bigger. They move around faster and take up more space.

Particles in a liquid are not halfway between solid and gas. They are closer to solids as particles are closely packed.

Models do not represent reality. They are not a perfect representation but help to understand a concept.

Evaporation is not the same as boiling. Boiling happens at a fix temperature for a pure substance, evaporation can happen at any temperature if particles posses enough energy to escape the surface of the liquid.

**Key questions**

How has the model of the atom changed?

Describe the arrangement and energy of the states of matter.

How can density of a liquid, regular and irregular solid be measured?

What is internal energy and how does change of state effect it?

What is pressure?

Development of the model of the atom

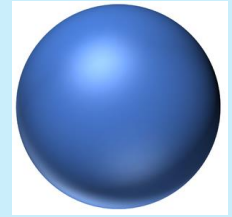
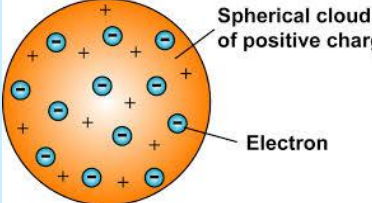
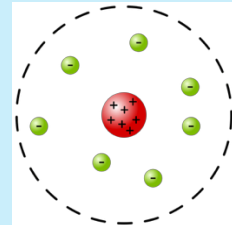
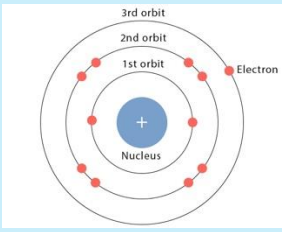
<p><b>Dalton (1803)</b></p>		<p>Suggested atoms are indivisible solid spheres based only on observations</p>
<p><b>JJ Thomson – plum pudding model (1897)</b></p>	 <p>Spherical cloud of positive charge Electron</p>	<p>Discovered electrons in atoms and suggested the 'plum pudding' model for an atom - made up of electrons scattered throughout a spherical cloud of positive charge.</p>
<p><b>Rutherford – nuclear model (1911)</b></p>		<p>Rutherford fired positively charged alpha particles at a thin sheet of gold foil. Most passed through with little deflection, but some deflected at large angles. This was only possible if the atom was mostly empty space, with the positive charge (and mass) concentrated in the centre: the nucleus. Led to the discovery of positively charged nucleus with electrons orbiting this nucleus.</p>
<p><b>Bohr (1913)</b></p>	 <p>3rd orbit 2nd orbit 1st orbit Electron Nucleus</p>	<p>Bohr modified Rutherford's model of the atom by stating that electrons moved around the nucleus in orbits of fixed sizes and energies. (Electron shells)</p>

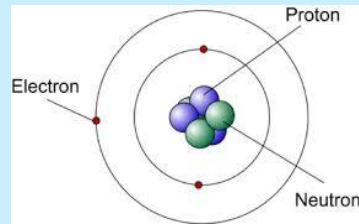
<p><b>Chadwick (1932)</b></p>	 <p>Proton Neutron Electron</p>	<p>Discovered neutrons in the nucleus. Positively charged particle called proton.</p>
-------------------------------	--	---

Structure of atom

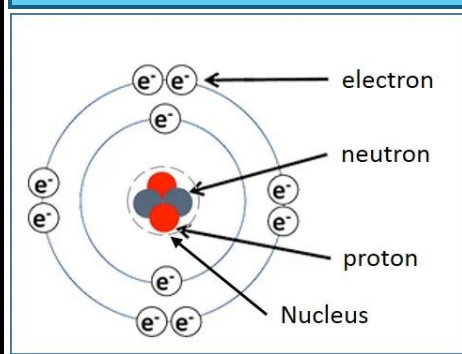

Size of atoms

Atoms have a radius of 0.1nm ( $1 \times 10^{-10} \text{m}$ )  
 The radius of the nucleus is 1/10 000 of that of an atom ( $1 \times 10^{-14} \text{m}$ )

Subatomic particles

Subatomic particle	Mass	Charge
Proton	1	+1
Electron	1/2000 or very small	-1
Neutron	1	0

Isotopes

Atoms of the same element with the same number of protons and electrons but different numbers of neutrons

Charge of atoms

The number of protons (+) and electrons (-) are always equal in an atom – so atoms have no overall charge

States of matter

Internal energy

	Solid	Liquid	Gas
Arrangement of Particles	regular pattern close together	irregular pattern close together	irregular pattern far apart
Movement of Particles	vibrate around their fixed positions	move past each other in random directions	random directions at a range of speeds
Diagram			

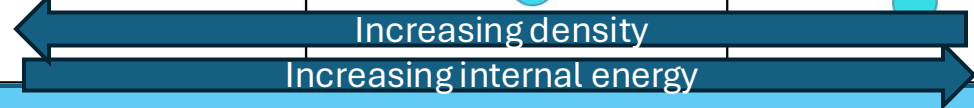

Changes of state

- Melt: solid → liquid
- Freeze: liquid → solid
- Boil: Liquid → gas (at boiling point)
- Evaporate: liquid → gas
- Condense: gas → liquid
- Sublimate: solid → (straight to) gas
- Mass conserved for all these changes
- Changes of state = physical changes - material recovers original properties if change reversed (chemical changes don't)

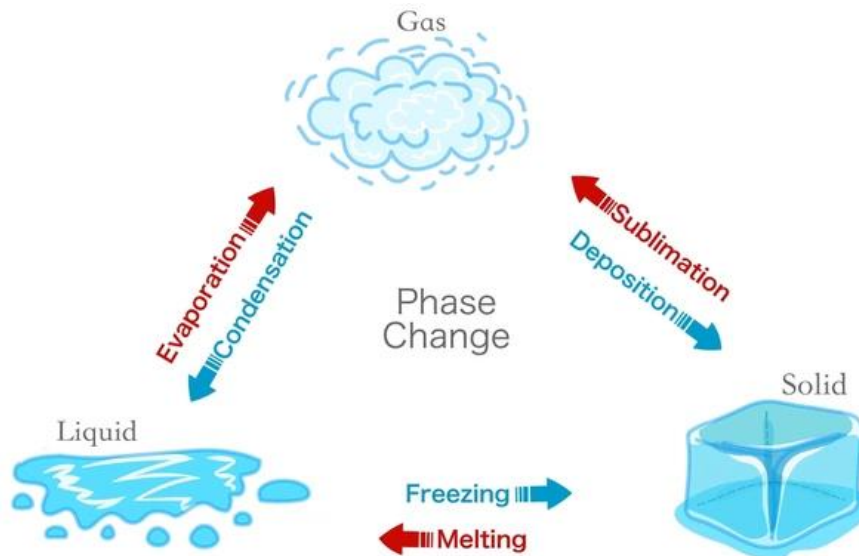

Internal energy: energy stored by particles (atoms & molecules)

Internal energy =

kinetic energy + potential energy of particles

Heating → increases energy of particles by:

- raising temperature = increase in kinetic energy
- producing change of state → as distance between particles increases, potential energy increases

Particle motion in gases

Particles in a gas are constantly moving – so store kinetic energy. They collide with the walls of the container, and exert a force when they do. The total force exerted on a certain area of the wall is the gas pressure.

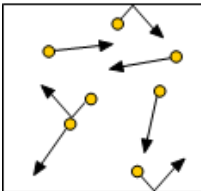

cold  
Lower pressure

The average kinetic energy of the particles is related to the temperature of the gas. The higher the temperature, the more kinetic energy they have. This means they move faster. Therefore, there are more collisions with the container walls and they exert a greater force when they collide with the walls. Thus, increasing the temperature of a gas (keeping the volume the same) increases the pressure of the gas.

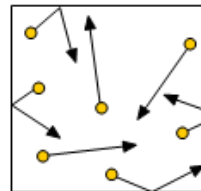

hot  
Higher pressure

The pressure from gas molecules may increase if there are more molecules colliding each second or if the molecules are moving faster.

Density

Density of regular solid

Density of irregular solid

Density describes how closely packed the particles are in a solid, liquid or gas. Scientists can measure how tightly packed the particles are by measuring **the mass of a certain volume** of the material. Usually measured in kilograms per metre cubed ( $\text{kg/m}^3$ ) or grams per centimetre cubed ( $\text{g/cm}^3$ ).

Density can be calculated using the equation:

$$\text{density} = \frac{\text{mass}}{\text{volume}}$$

$$p = \frac{m}{v}$$

This is when:

- density ( $p$ ) is measured in kilograms per metre cubed ( $\text{kg/m}^3$ )
- mass ( $m$ ) is measured in kilograms (kg)
- volume ( $V$ ) is measured in metres cubed ( $\text{m}^3$ )

- Measure mass using balance
- Measure length, width, height with ruler or vernier calipers and calculate volume  $l \times w \times h$
- Use density = mass / volume

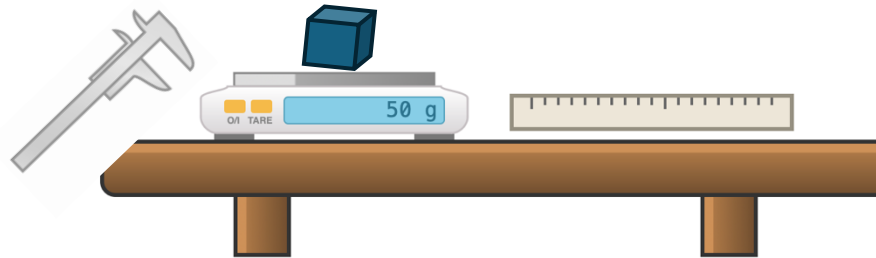

Displacement method – small item

- Measure mass using balance
- Half fill measuring cylinder with water and measure volume
- Add object carefully and measure new volume
- Difference in volume = volume of object
- Use density = mass / volume

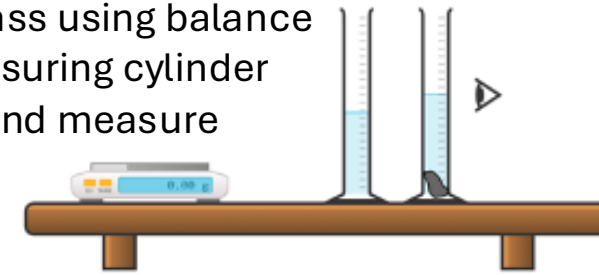

Displacement method – large item

- Measure mass using balance
- Fill displacement can with water up to spout
- Add object carefully and collect displaced water
- Measure volume of displaced water with measuring cylinder = volume
- Use density = mass / volume

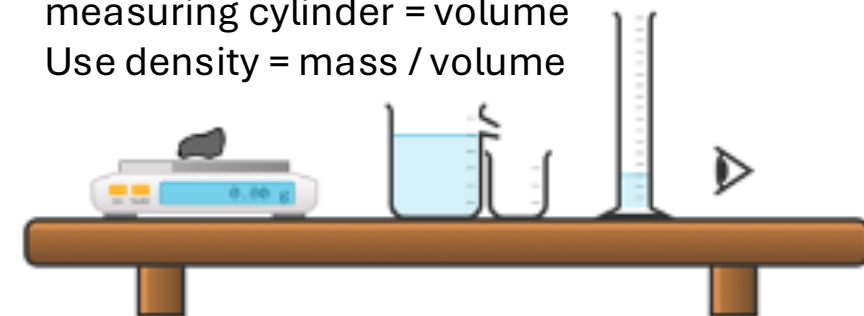

Density of liquid

- Measure mass of empty measuring cylinder using balance
- Fill measuring cylinder with liquid and measure mass
- Find difference between full and empty
- Measure volume
- Use density = mass / volume

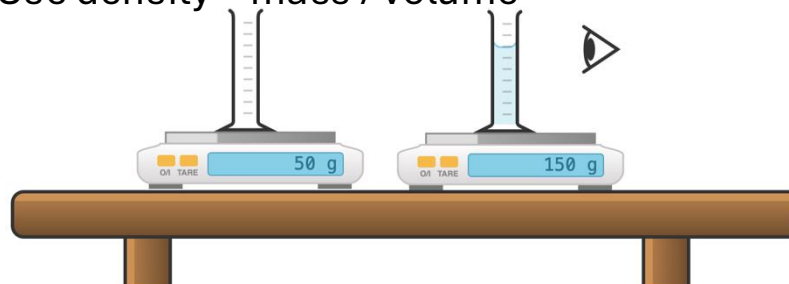

**Specific latent heat**

$E = m \times L$

<b>Specific latent heat</b>	The energy needed to change the state of one kilogram of a substance with no change in temperature
<b>Specific latent heat of fusion</b>	The energy needed to change the state of one kilogram of a substance <b>from a solid to a liquid</b> with no change in temperature
<b>Specific latent heat of vaporisation</b>	The energy needed to change the state of one kilogram of a substance <b>from a liquid to a gas/vapour</b> with no change in temperature

Energy required to change the state of the substance depends on the mass and its specific latent heat

Energy = mass x specific latent heat  
( $E = m \times L$ )

- Energy (J)
- Mass (kg)
- Specific latent heat (J/kg)

The graph is horizontal at two places. These are where energy is being used to break the bonds between the particles to change the state, rather than increase the speed (and so temperature) of the particles.

The longer the horizontal line, the more energy has been used to cause the change of state. The amount of energy represented by these horizontal lines is equal to the latent heat.

**Key words**

<b>Kinetic energy</b>	The energy associated with movement. The kinetic energy of particles in any state of matter is related to the temperature of the matter.
<b>Temperature</b>	A measure of the average kinetic energy of particles in a substance. As temperature increases, the average kinetic energy increases. Note: temperature does not measure the potential energy of particles, just their kinetic energy.
<b>Heating</b>	Heating is one way to transfer energy from one store to another.

**Graph of a cooling curve**

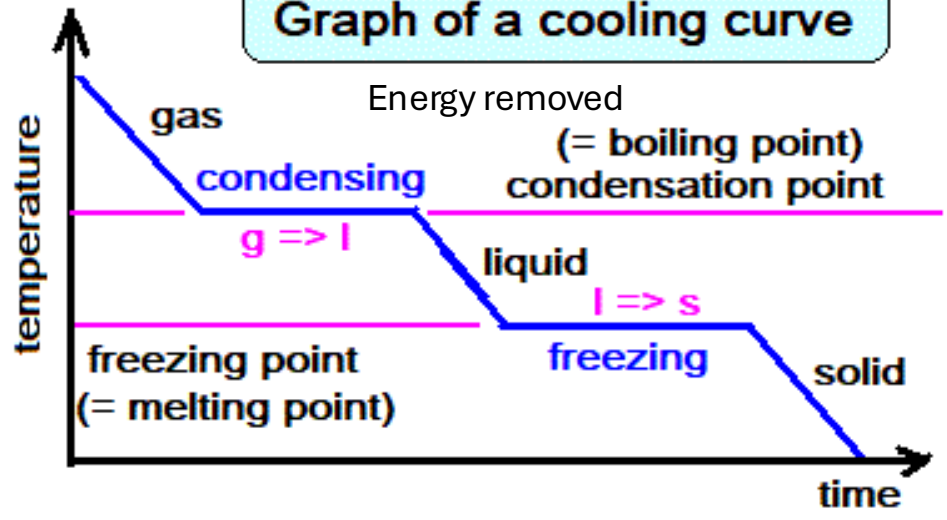

**Graph of a heating curve**

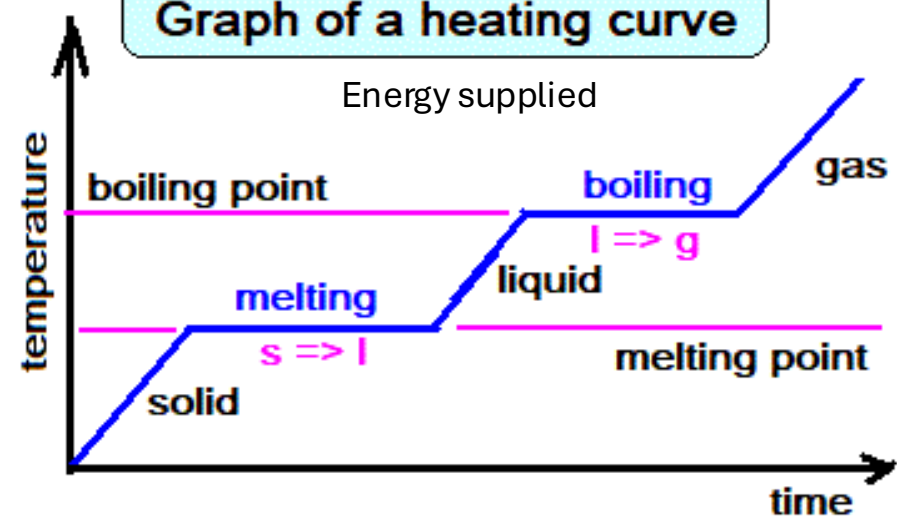

Key terms	
<b>Pressure</b>	Pressure is caused by the force exerted by particles in a gas when they hit the walls of a container.
<b>Atmospheric pressure</b>	The pressure from air particles in the atmosphere colliding with a surface. At sea level this is 100,000 N/m <sup>2</sup>
<b>pV = constant</b>	P = Pressure (Newtons per meter squared (N/m <sup>2</sup> )) or Pascals (Pa) V = Volume (m <sup>3</sup> )
<b>P<sub>1</sub> V<sub>1</sub> = P<sub>2</sub> V<sub>2</sub></b>	<i>P<sub>1</sub> = pressure before the change</i> <i>V<sub>1</sub> = volume before the change</i> <i>P<sub>2</sub> = Pressure after the change</i> <i>V<sub>2</sub> = volume after the change</i>

**Pressure**

$$\text{Pressure} = \frac{\text{Force}}{\text{Area}}$$

Pressure in pascals (Pa) or newtons per metre squared (N/m<sup>2</sup>)

Force in newtons (N)

Area in metres squared (m<sup>2</sup>)

**Pressure and volume**

A gas can be compressed or expanded by changes in pressure. The pressure produces a force at right angles to the wall of the container. If the volume of gas decreases the pressure will increase if the temperature remains constant. Volume is inversely proportional to pressure. This is because the same number of particles collide with the walls of the container more frequently as there is less space. However, the particles still collide with the same amount of force. If the volume of the gas is expanded, pressure will decrease if the temperature remains constant.

This is because the same number of particles collide with the walls of the container less frequently as there is less space. However, the particles still collide with the same amount of force.

For a fixed mass of gas at a constant temperature Pressure x volume = constant

This is also known as Boyles Law. The change in volume or pressure can be calculated using the equation:  $P_1 V_1 = P_2 V_2$

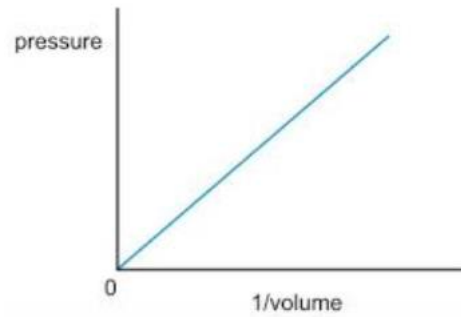
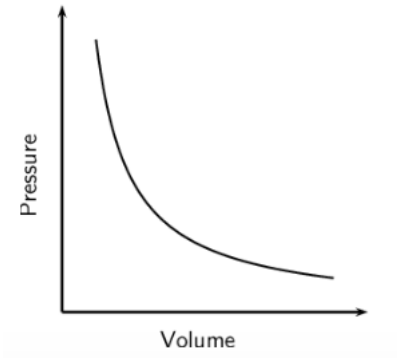

**Work and energy**

Pressure can be increased by:

- Increasing the temperature (Increasing the force of the collisions)
- Decreasing the volume (Increasing the number of collisions per second)

Forces applied to particles result in a transfer of energy. If a gas is compressed work is done on the gas. Doing work on a gas increases internal energy of the gas and causes an increase in temperature. E.G. if a tyre is inflated with a pump there would be work done so the internal energy of the gas increases which causes an increase of the temperature of the gas.



Energy transfers	Calculating efficiency	Kinetic energy calculations	Ee calculations	Linking equations	Specific heat capacity	Specific heat capacity practical
------------------	------------------------	-----------------------------	-----------------	-------------------	------------------------	----------------------------------

**Key Words**

Key Word	Definition
<b>Efficiency</b>	The ratio of useful output energy transfer to total energy input.
<b>Elastic Potential Energy</b>	The store of energy that stretched or compressed objects experience.
<b>Kinetic Energy</b>	The store of energy that all moving matter has.
<b>Specific Heat Capacity</b>	The amount of energy required to raise the temperature of 1kg of a substance by 1°C.
<b>Spring Constant</b>	A measure of a spring's stiffness.

**Misconceptions**

Doubling the speed of a moving object does not double the kinetic energy  
 Speed is squared

The only type of potential energy is not gravitational  
 Potential is any that is stored up ready to be release (elastic, chemical, nuclear...)

Elastic potential energy is not only stored in stretched objects  
 It is also stored in compressed elastic objects

Heat and temperature are not the same thing  
 Heat (joules), temperature (°C) how hot/cold object is, change in heat depends on change in temperature, mass, specific heat capacity

**Key questions**

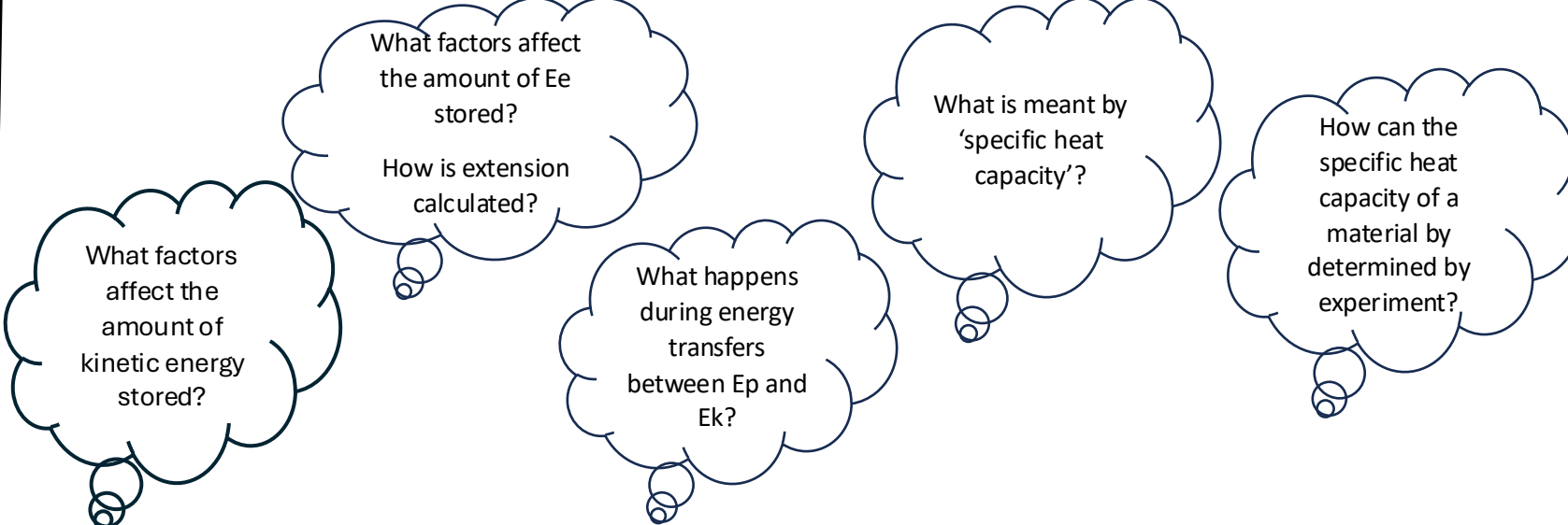

## Equations to learn

**Efficiency**  
 Efficiency =  $\frac{\text{Useful energy output}}{\text{Total energy input}}$  or  $\frac{\text{Useful power output}}{\text{Total power input}}$

**Kinetic energy**  
 Kinetic energy (J) =  $0.5 \times \text{mass (kg)} \times \text{velocity}^2 \text{ (m/s)}$

**Gravitational potential energy**  
 Ep (J) =  $m \text{ (kg)} \times g \text{ (N/kg)} \times h \text{ (m)}$

## Equations provided

**Elastic potential energy**  
 Ee (J) =  $0.5 \times \text{spring constant (N/kg)} \times \text{extension}^2 \text{ (m)}$

**Specific heat capacity**  
 Energy (J) =  $\text{mass (kg)} \times c \text{ (J/kg}^\circ\text{C)} \times \text{temperature change (}^\circ\text{C)}$

## CFIFA – setting out calculations

Set out calculations using CFIFA to maximise marks:

**Convert** Have standard units been used? Clearly show how you convert them e.g.  $\times 100$ ,  $\div 1000$

**Formula** Write the formula (equation) as you've learnt it/as it is on the equation sheet e.g.  $W = F \times s$

**Insert** Insert the values from the question replacing the parts of the formula above e.g.  $10 = F \times 5$

**Fine tune** Show any rearranging needed (write what every you put into your calculator) e.g.  $\frac{10}{5} = F$

**Answer** Give your answer, check if you need to give unit or to certain number of significant figures etc.

## Efficiency

- Useful energy – Any energy that is transferred into a store that is used for the intended purpose.
- Wasted energy – Any energy that is **dissipated**. Calculated efficiency will be a decimal.

## Storing elastic potential energy

Two forces must be applied to elastic object to store Ee      Ee stored depends on EXTENSION  
 Compression or extension will increase store of Ee      Ee stored depends on spring constant

## Changes in energy

As one store decreases one or more stores increase (conservation of energy). For a child on a trampoline:  
 100 J of Ep at top of bounce will transfer to 100 J of Ek at bottom and 100 J of Ee on trampoline, some energy will be dissipated to thermal in surroundings, but total will equal 100 J

## Specific heat capacity

Energy required to raise the temperature of 1kg of a material by 1°C (J/kg °C)

## Specific heat capacity practical

- $c = \frac{\Delta E}{m \Delta \theta}$
- Measure mass of block using balance
- Connect immersion heater to powerpack and joulemeter, put in block with thermometer
- Measure start temperature of block
- Measure electrical energy transferred to block using joulemeter
- Measure end temperature and find change
- Use equation to calculate the SHC

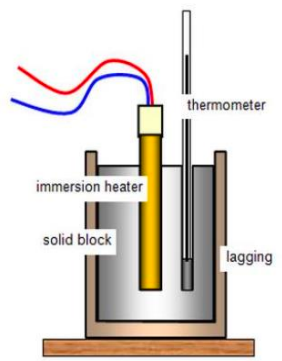

Calculated value likely to be higher, improve accuracy by insulating block

Circuits recap	LDRs	Thermistors	IV characteristics	IV characteristics	Diodes	Potential dividers	EVQ and energy transfers	Electrical power equations
----------------	------	-------------	--------------------	--------------------	--------	--------------------	--------------------------	----------------------------

### Key Words

Key Word	Definition
<b>Ampere (Amps)</b>	The unit of current.
<b>Coulomb</b>	The unit of charge.
<b>Electrical Current</b>	The rate of flow of electrical charge
<b>Electrical Work</b>	When charge flows in a circuit, electrical work is said to be done.
<b>Ohms</b>	The unit of resistance.
<b>Potential Difference</b>	The energy transferred to or by each unit of charge, measured in volts.
<b>Power</b>	The rate of energy transfer. In electrical components, the power is found by multiplying p.d. by current.
<b>Resistance</b>	A measure of the opposition to current flow.
<b>Volt</b>	The unit of potential difference.
<b>Work</b>	Transfer of energy.

### Misconceptions

Current is not used up as it flows around a circuit

Cells and batteries do not store current. Cells and batteries store chemical energy.

Potential difference does not flow through components, it measures the difference in energy across the component.

A cell or battery does not produce a fixed current, the current depends on the potential difference of the cell and resistance of the circuit

### Key questions

What is an LDR/thermistor and how does its resistance change?

How can the IV characteristic of a resistor/ filament bulb/ diode be identified?

What effect do diodes have on circuits?

What is an ohmic conductor?

What is electrical power and how can it be calculated?

Components	
Component	Description
<b>Diode</b>	A component that only allows current to flow through in the forward direction. They have very large resistances in the reverse direction.
<b>Filament Lamp</b>	A light emitting component consisting of an enclosed metal filament. Its resistance increases as the filament's temperature increases.
<b>Light Dependent Resistor (LDR)</b>	A light sensitive component whose resistance increases as its temperature decreases. (Light Up Resistance Down, LURD)
<b>Ohmic Conductor</b>	A conductor whose current flow is directly proportional to the potential difference across it, when held at a constant temperature.
<b>Thermistor</b>	A temperature dependent component, whose resistance increases as its temperature decreases. (Temperature Up Resistance Down, TURD)
<b>Required practical – IV characteristics</b>	

Equations	
Energy Transferred – this depends on how long the appliance is on for and its power. • Energy transferred (J) = power (W) × time (s)  Energy is transferred around a circuit when the charge moves. • Energy transferred (J) = charge flow (C) × potential difference (V) • Power (W) = potential difference (V) × current (A) • Power (W) = current <sup>2</sup> (A) × resistance (Ω)	$E = Pt$  $E = QV$ $P = VI$ $P = I^2R$
From circuits 1: $Q = It$ $V = IR$  Common conversions: 1kW = 1000 W 1mA = 0.001A	

### IV practical method

1. Set up the equipment as shown in the diagram.
2. Record the current from the ammeter and potential difference from the voltmeter.
3. Adjust the variable resistor.
4. Record the new current and potential difference.
5. Repeat this until you have 4-6 pairs of readings.
6. Swap the connections to reverse the polarity of the battery.
7. Repeat steps 3-4 until you have 4-6 negative pairs or readings.
8. Plot a graph of current against potential difference for each component.
9. Repeat the experiment replacing the fixed resistor with a filament lamp and diode.

### Graphs of I-V Characteristics for Components in a Circuit

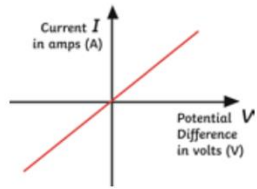
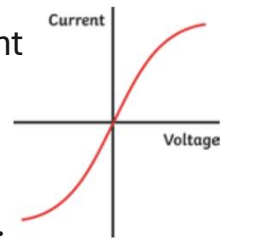
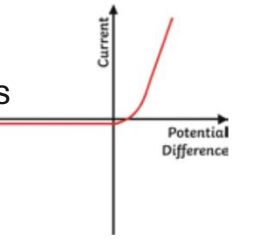
1. Ohmic conductor (fixed resistor): the current is directly proportional to the potential difference - it is a straight line (at a constant temperature).
 
2. Filament lamp: as the current increases, so does the temperature. This makes it harder for the current to flow. The graph becomes less steep.
 
3. Diode: current only flows in one direction. The resistance is very high in the other direction which means no current can flow.
 

**Safety:**  
 Disconnect circuit when not taking readings to prevent overheating  
 Wires/components may get hot, allow to cool before handling

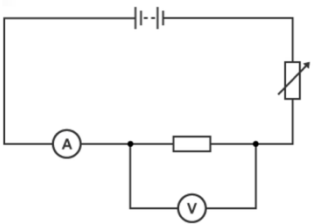

## Series and parallel circuits

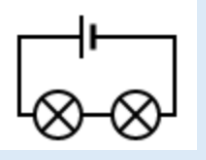

Series circuits have one loop.

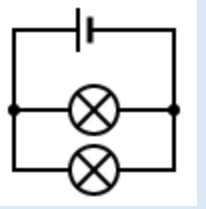

Parallel circuits have two or more loops.

Current

Series: is the same everywhere.  
Parallel: is split between loops

Potential difference

Series: pd of power supply is shared between components.  
Parallel: is same across each loop

Resistance

Series: total R = sum of resistances of all components  
Parallel: total R is reduced as current can follow more paths

## Energy transfers

All electrical appliances transfer energy from one store to another. The amount of energy transferred depends on the power of the appliance and how long it is on for ( $E=Pt$ ). Energy is transferred around a circuit when a charge flows ( $E=QV$ ).

## Resistance graphs

Thermistors – resistance decreases as temperature increases.  
Uses: thermostats, ovens, digital thermometers, car engines

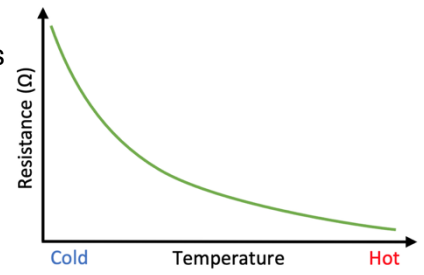

Light dependent resistors – resistance decreases as light intensity increases.  
Uses: streetlights, automatic security lighting, photographic light meters

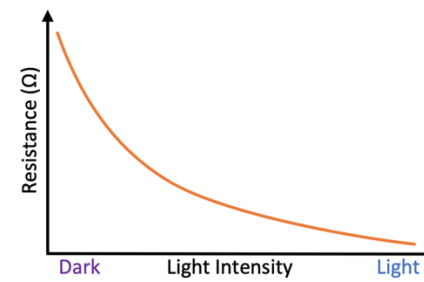

Fixed resistor (at constant temperature) – steeper gradient = lower resistance

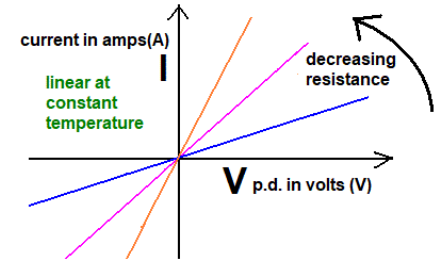





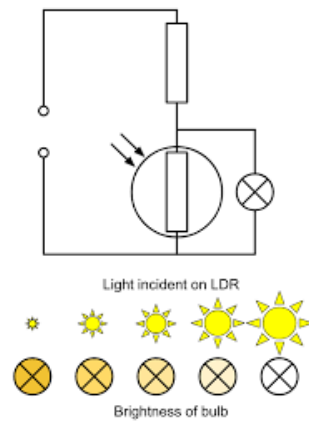



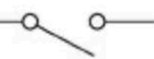



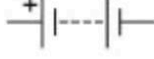

## Potential dividers

A potential divider splits the potential difference of a power source between two components. The potential difference across each resistor depends upon its resistance: The resistor with the largest resistance will have a greater potential difference than the other one. Used with LDR/thermistor to turn on light/heater.

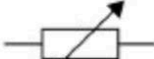

## Circuit components

	switch (open)		lamp
	switch (closed)		fuse
	cell		voltmeter
	battery		ammeter
	diode		thermistor
	resistor		variable resistor
	variable resistor		LDR
	LED		

## Triple only key words

Key word	Definition
<b>Attraction</b>	A force pulling two opposite charges together, when they are brought near each other.
<b>Conductor</b>	Material through which electrical charge flow easily. Have low resistances.
<b>Electric field lines</b>	Lines representing an electric field, that point in the direction in which a positive charge would experience an electric force.
<b>Electric field</b>	A region/area in which a charge will experience a non-contact, electric force. All charged objects have an electric field around them, and this field is stronger the closer you are to the charge.
<b>Insulator</b>	Material through which electric charges do not flow easily. Have high resistances.
<b>Non-Contact Force</b>	A force experienced between two separated objects. Examples include gravity, and magnetic and electrostatic forces.
<b>Repulsion</b>	Caused when two like-charges are brought near each other.
<b>Static charge</b>	The charge caused by an imbalance of positive and negative charges in, or on, an object's surface. It is often caused by electrons being rubbed from one surface onto another.

## Electric fields

- Like charges repel
- Opposite charges attract
- A charged object will experience a non-contact force from another charged object. This force is called an electrostatic force

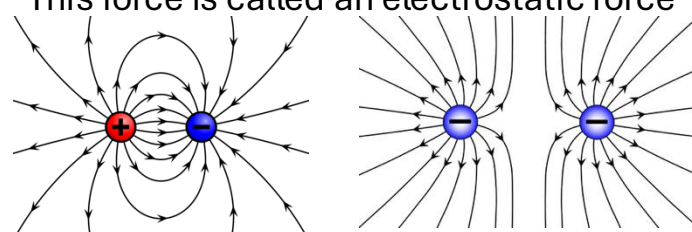

- All charged objects have an electric field around them. This is a region where charges experience a force
- Field lines point away from positive charges and towards negative charges as they show the direction a positive charge would move in the field
- The closer together the arrows are, the stronger the field, meaning that the field is stronger closer to the charge
- The force gets stronger as the distance between the object decreases.

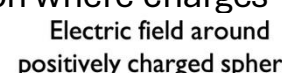

Electric field around positively charged sphere.



Electric field around a negatively charged sphere

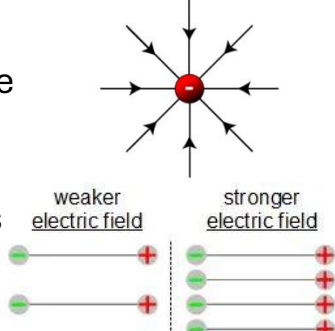

weaker electric field      stronger electric field

## Static electricity

- When certain insulating materials are rubbed together, they both become charged because electrons are transferred from one material to the other
- The material **gaining** electrons becomes **negatively** charged
- The material **losing** electrons becomes **positively** charged
- The size of the charge on each material is the same magnitude but opposite in direction (+ vs -)
- The build up of charge on an insulator can lead to sparking e.g. lightning
- The greater the charge on an isolated object, the greater the potential difference between the object and the earth
- If the potential difference is large enough, the charges move through the air causing a spark across the gap between the object and any earthed conductor brought near it

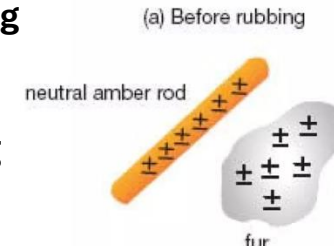

(a) Before rubbing  
neutral amber rod      fur

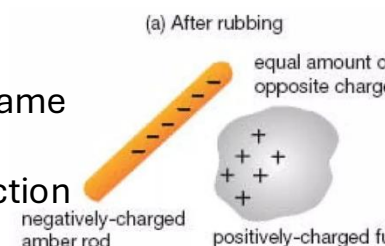

(a) After rubbing  
equal amount of opposite charge  
negatively-charged amber rod      positively-charged fur



<b>Background radiation</b>	<b>Types of radiation</b>	<b>Nuclear decay equations</b>	<b>Half life and activity</b>	<b>Hazards of radiation</b>	<b>Uses of radiation</b>	<b>Medical uses</b>	<b>Fission and fusion</b>
-----------------------------	---------------------------	--------------------------------	-------------------------------	-----------------------------	--------------------------	---------------------	---------------------------

**Key Words**

Key Word	Definition
<b>Activity</b>	The rate at which an unstable nucleus decays.
<b>Atomic Number</b>	The number of protons found in an atom of a specific element. Each element has a different atomic number.
<b>Becquerel</b>	The unit of radioactive activity. 1 Bq = 1 decay per second = 1 count per second
<b>Count-Rate</b>	The number of decays that a detector measures per second.
<b>Geiger-Muller Tube</b>	A detector that measures the count-rate of a radioactive sample.
<b>Ions</b>	Atoms with a charge due to the loss or gain of electrons.
<b>Isotopes</b>	Atoms with the same number of protons but different numbers of neutrons. The atomic number is the same, but the mass number is different.
<b>Mass Number</b>	The number of protons and neutrons in an atom.
<b>Radioactive Decay</b>	The random process involving unstable nuclei emitting radiation to become more stable.

**Misconceptions**

- Being irradiated does not make you radioactive
- Exposure to radiation does not cause immediate symptoms
- Radiation cannot be neutralised
- All radiation does not have the same danger level

**Key questions**

- What are the types of radiation and their properties?
- How is nuclear decay represented as an equation?
- What is half-life and how does it effect activity?
- What are the hazards of radiation and how can they be minimised?
- What are the uses of radiation linked to their properties?

**Key words**

Key Word	Definition
<b>Alpha Particle</b>	A positively charged particle consisting of two protons and two neutrons.
<b>Beta Particle</b>	A high speed electron that a nucleus emits when a neutron converts into a proton.
<b>Gamma Ray</b>	Electromagnetic radiation emitted from a nucleus.
<b>Half-Life</b>	The time it takes for the number of unstable nuclei of an isotope in a sample to halve, or the time it takes for the initial count rate of a sample of the isotope to halve.

**Radiation and hazard level**

Alpha = more dangerous inside body due to high ionising power and at very short distances. Less dangerous outside body as it cannot penetrate skin and as distance to source increases.

Beta = less dangerous inside body as some radiation can escape and at large distances. More dangerous outside body as it can penetrate skin and at moderate distances.

Gamma = less dangerous inside body as most will pass out and is least ionising. More dangerous at long distances as it has greatest range in air and can penetrate skin.

**Radiation Properties**

	Symbol	Penetrating power	Ionising power	Range in air
<b>Alpha</b>	$\alpha$	Skin/paper	High	< 5 centimetre (cm)
<b>Beta</b>	$\beta$	3 mm aluminium foil	Moderate	≈ 1 metre (m)
<b>Gamma</b>	$\gamma$	Lead/concrete	Low	> 1 kilometre (km)
<b>Neutron</b>	n	An uncharged particle		

**Nuclear decay equations**

- Nuclear equations: represent radioactive decay.
- Alpha particle:  ${}^4_2\text{He}$
- Beta particle:  ${}^0_{-1}\text{e}$
- Emission of different types of nuclear radiation may cause change in mass and /or charge (atomic number) of nucleus. Eg:  

$${}^{219}_{86}\text{radon} \longrightarrow {}^{215}_{84}\text{polonium} + {}^4_2\text{He}$$
- Alpha decay decreases both mass & charge of nucleus (mass -4, atomic number -2)
- $${}^{14}_6\text{carbon} \longrightarrow {}^{14}_7\text{nitrogen} + {}^0_{-1}\text{e}$$
- Beta decay → no change in mass of nucleus but charge increases (atomic number +1)
- Gamma emission → no change in mass or charge

**Radioactive hazards**

**Radioactive contamination:** unwanted presence of materials containing radioactive atoms on/in other materials. Hazard is due to: The decay of the contaminating atoms. Type of radiation emitted affects level of hazard.

**Irradiation:** exposing object to nuclear radiation but object doesn't become radioactive. Must take suitable precautions against any hazard presented by radioactive sources. E.g. concrete shielding, lead shielding (aprons), keeping a safe distance away and limiting time..

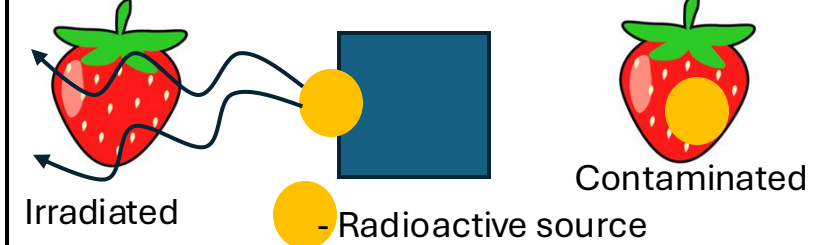

**Key words**

Key Word	Definition
<b>Emission</b>	Releasing or giving out. Nuclear radiation is emitted from the nucleus during radioactive decay.
<b>Ionisation</b>	The process of making an ion by 'knocking off' electrons. Ionising radiation causes this and is dangerous in living organisms as it can cause mutations of DNA increasing risk of cancer
<b>Penetration</b>	Passing through a material. Different types of nuclear radiation can penetrate different materials and are absorbed by certain materials.
<b>Peer review</b>	where other scientists check the methods and analysis performed, on the findings of studies into the effects of radiation on humans

**Uses of radiation**

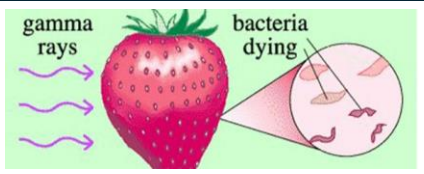
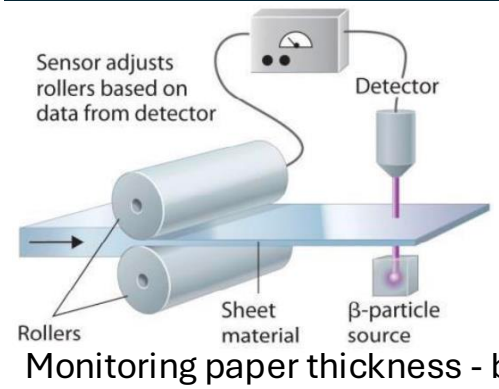

Smoke detectors - alpha

The half-life of a radioactive source is:

- the time it takes for the number of nuclei of the isotope in a sample to halve
- the time it takes for the count rate (or activity) from a sample containing the isotope to fall to half its initial level.

Radioactivity is a random process – cannot be predicted when any one nucleus will decay but half-life is a constant so allows activity of many nuclei to be predicted during the decay

Half-life and stability:  
 Less stable → shorter half-life  
 More stable → longer half-life

Half-life and radioactivity:  
 Shorter half-life → more active  
 Longer half-life → less active

(HT only) Net decline can be given as a ratio:  $\text{net decline} = \frac{\text{initial number} - \text{number after X half-lives}}{\text{initial number}}$

Example: There were initially 80 nuclei of an element with a half-life of 15 minutes. What was the net decline after 3 half-lives?

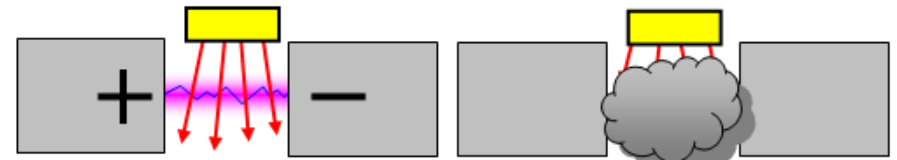
$$\frac{80}{2} = 40 \quad \frac{40}{2} = 20 \quad \frac{20}{2} = 10 \quad \frac{80-10}{80} = \frac{7}{8}$$

Cancer treatment – gamma  
 Detecting cracks in underground pipes - gamma

**Half life**

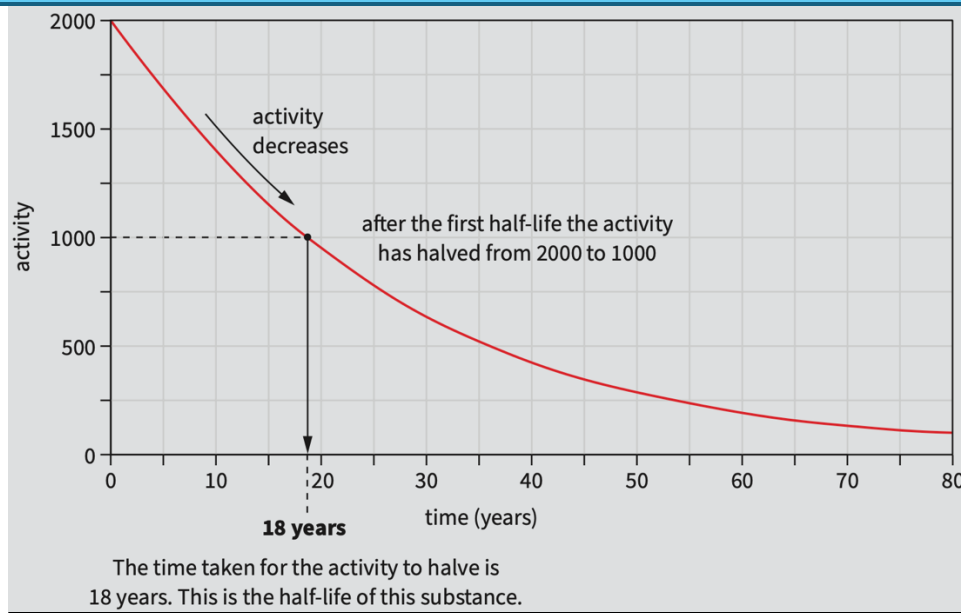

To find half life from a graph:

- Find where decay curve starts on y axis (2000 above)
- Halve the start number (1000 on above) and read from y axis across to decay curve
- From decay curve read down to time on x axis (18 years on above) = half life

Key words	
Key word	Definition
<b>Background radiation</b>	Radiation that is found all around us and originates from natural sources such as rocks and cosmic rays, as well as from man-made sources such as nuclear weapons testing and accidents.
<b>Chain reaction</b>	The process of neutrons released by a fission reaction, being absorbed by another unstable, large nuclei, and inducing further fission.
<b>Fission products</b>	Fission produces two smaller nuclei, two or three neutrons and gamma rays. All these products are released with kinetic energy.
<b>Nuclear explosions</b>	Nuclear explosions in nuclear weapons are caused by an uncontrolled chain reaction which results in vast quantities of energy being produced in a very short period.
<b>Nuclear fission</b>	The splitting of a large and unstable nucleus into two smaller and more stable nuclei to produce energy.
<b>Nuclear fusion</b>	The joining of two small, light nuclei to form a larger, heavier one and release energy.
<b>Sieverts</b>	The unit used for radiation dosage
<b>Spontaneous fission</b>	Fission that occurs without the absorption of a neutron. Spontaneous fission is rare usually, fission is induced with a neutron.

**Nuclear fission**

- Nuclear fission: splitting of a large and unstable nucleus (e.g. uranium or plutonium).
- Spontaneous fission is rare - usually for fission to occur the unstable nucleus must first absorb a neutron.
- The nucleus undergoing fission splits into two smaller nuclei, roughly equal in size, and emits two or three neutrons plus gamma rays and energy.
- All fission products have kinetic energy.

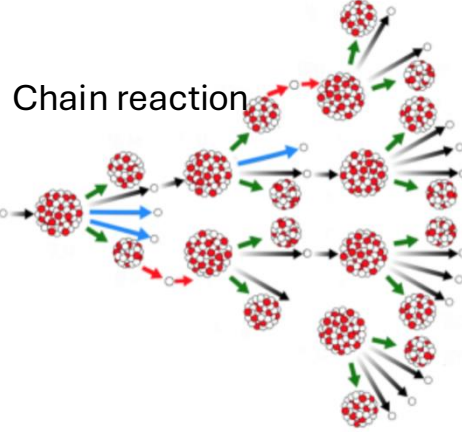
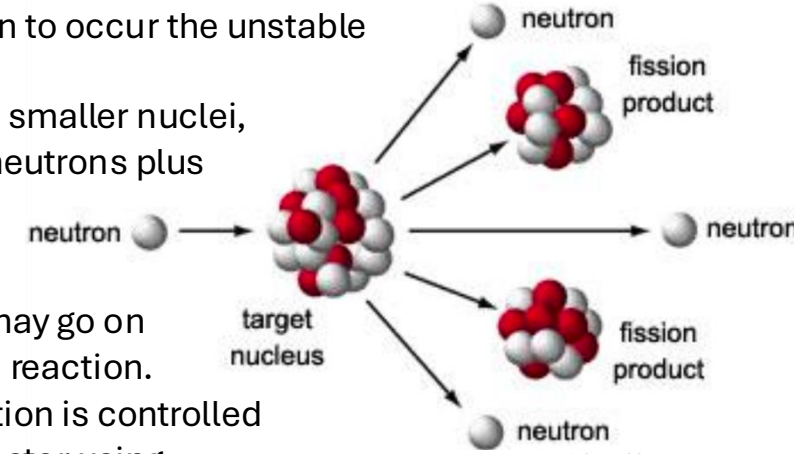

- The neutrons may go on to start a chain reaction.
- The chain reaction is controlled in a nuclear reactor using control rods to control the energy released.
- The explosion caused by a nuclear weapon is caused by a uncontrolled chain reaction.

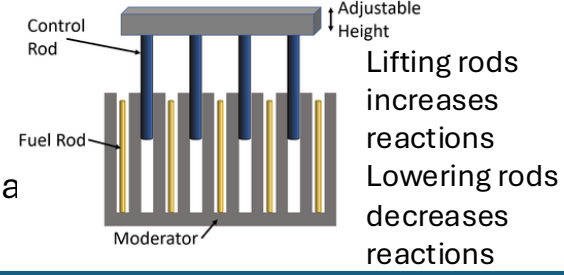

**Nuclear fusion**

- Nuclear fusion: two light nuclei join to form a heavier nucleus.
- Some of the mass of the smaller nuclei is converted into energy.
- Some of this energy may be the energy of emitted radiation.
- Because all nuclei have positive charge, very high temperatures and pressures are needed to bring them close enough for fusion to happen.
- Occurs in stars, has been done on Earth but does not produce a net output of electricity.

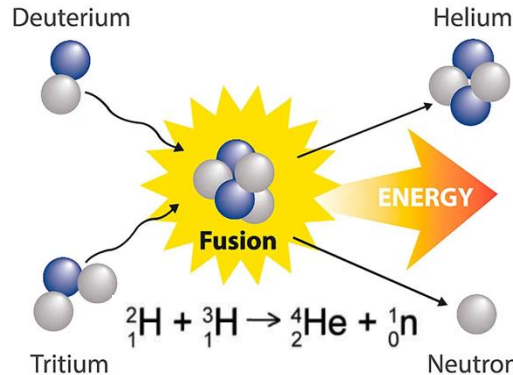

**Background radiation**

Background radiation: low intensity radiation around us all the time. Comes from:

- natural sources (rocks, cosmic rays from space)
- man-made sources (fallout from nuclear weapons testing and nuclear accidents)

Level of background radiation dose affected by occupation and location.

Radiation dose measured in Sieverts (Sv). 1000 millisieverts (mSv) = 1 sievert (Sv)

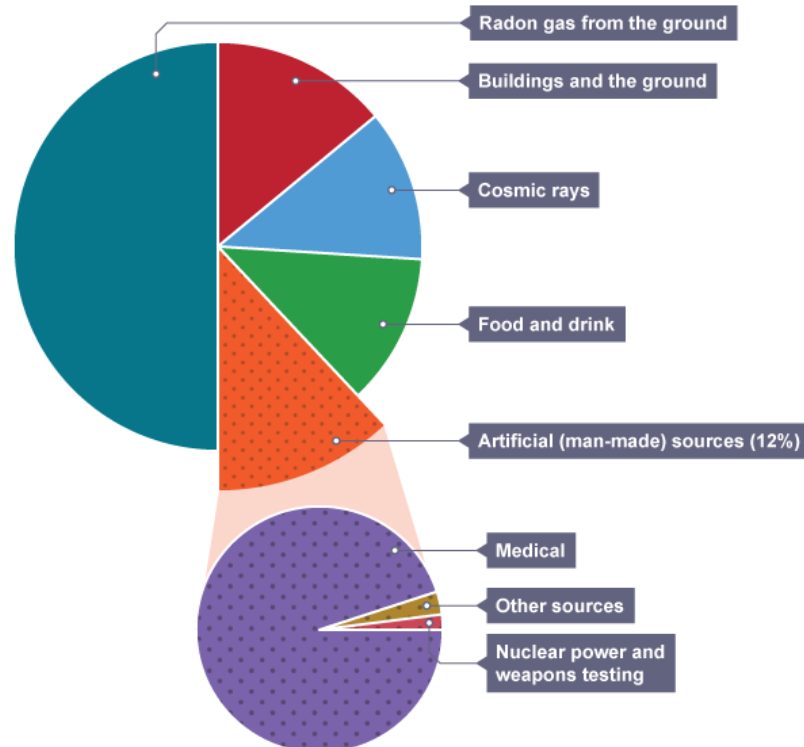

**Half-life and hazard**

- Radioactive isotopes have a wide range of half-life values.
- Sources containing nuclei that are most unstable have shortest half-lives – rapid decay and a lot of radiation emitted in a short time. However, radioactivity drops to a negligible level quickly.
- Sources with nuclei that are least unstable have longest half-lives – little radiation emitted each second but emit radiation for a long time so remain radioactive for a long time.

Considerations when selecting an isotope of a job:

Half-life – must be long enough to reach target location and remain measurable but not so long that it remains radioactive for long period

Radiation type – radiation type emitted must be measurable (not blocked) and pose least possible risk for the situation. Availability/cost

**Medical uses of radiation**

Nuclear radiations are used in medicine for the:

- exploration of internal organs (E.g. swallow a radioactive tracer which can then be detected by a sensor outside of the body – must be beta or gamma to pass through body and low half-life)

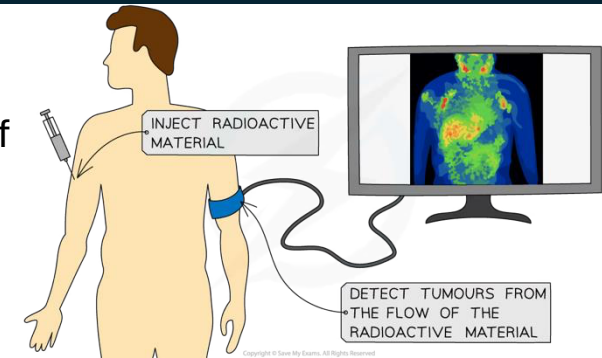
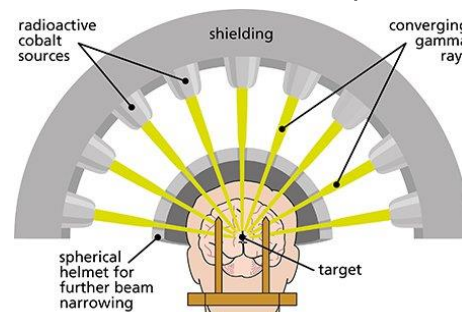

control or destruction of unwanted tissue (e.g. cancerous tumours – must be aimed from different directions so surrounding healthy tissue does not get too high a dose. Must be beta or gamma to penetrate through skin.)

<b>Working scientifically term</b>	<b>Definition</b>	<b>Example/how to improve</b>
Accurate / accuracy	Result that is close to the true value	Improve method, reduce random errors, use higher resolution equipment Use vernier calipers when measuring lengths to calculate volume. Add insulation when finding specific heat capacity Use jockey clips for length of wire
Valid result	Test only the effect of the independent variable on dependent variable	Use control variables - keep everything else the same between what you are testing
Random error	Results vary in unpredictable ways	Reduced by making more measurements, ignoring anomalies (results that don't fit pattern) and calculating a mean
Systematic error	Results differing from the true value by a consistent amount each time	Reading above/below eye line on measuring cylinder the same each time
Zero error (specific type of systematic error)	Equipment that should read 0 but doesn't	Ammeter / voltmeter / balance zero before using or read error value and add to final measure if it is a negative and subtract if it is a positive
Precise	Results that cluster closely	Small amount of variation between repeats, uncertainty value will be small
Uncertainty	How far above (+) or below (-) mean the results are	Difference (between highest and lowest result) $\div$ 2 Given as $\pm$ , add uncertainty value to mean to find highest result, subtract for lowest
Resolution	Smallest measurement that equipment can make	12.1°C = resolution of 0.1°C Higher resolution equipment will give more accurate result
Repeatable	Repeats under same condition by same investigator give similar pattern	Repeat investigation
Reproducible	Similar results are obtained by different investigators with different equipment	Ask someone else to repeat investigation